

# craster

## ASSEMBLY INSTRUCTIONS SV\_MOD21

<b>Product Name</b>	Stak Shelving Unit	
<b>Codes</b>	SV_MOD21_OB, SV_MOD21_ON, SV_MOD21_WN	
<b>Dimensions</b>	1231 x 450 x 1950mm / 48.5 x 17.7 x 76.8in	
<b>Components</b>	<ul style="list-style-type: none"> <li>❶ End Frame (x2)</li> <li>❷ Castor Wheel (x4)</li> <li>❸ M12 Washer (x4)</li> <li>❹ M12x30 (x4)</li> <li>❺ Crossbar (x4)</li> </ul>	<ul style="list-style-type: none"> <li>❻ M8x25 Button Screw (x16)</li> <li>❼ Top Frame (x1)</li> <li>❽ M8x50 Special Socket Screw (x8)</li> <li>❾ Shelf Panel (x5)</li> <li>❿ Shelf Bracket (x20)</li> </ul>
<b>Additional Tools</b>	5mm Allen Key 6mm Allen Key 18mm Ring Spanner	
<b>Guidance</b>	It is highly recommended that the product is assembled on a soft surface, by at least 2 people	

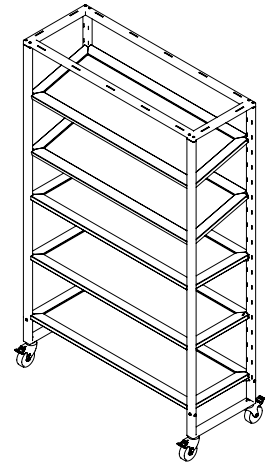

1. With the End Frame upside down, attach (x2) Castor Wheels with M12x30 & M12 Washer. Ensure castors are locked before attaching. ▲ Tighten to 100NM ▲
2. Repeat for second End Frame.

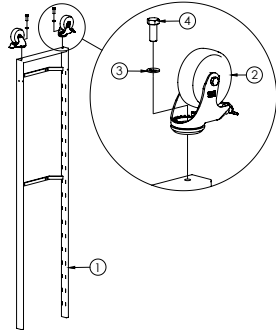

3. Attach (x4) Crossbars to the End Frames with M8x25 Button Screws. ▲ Tighten to 40NM ▲

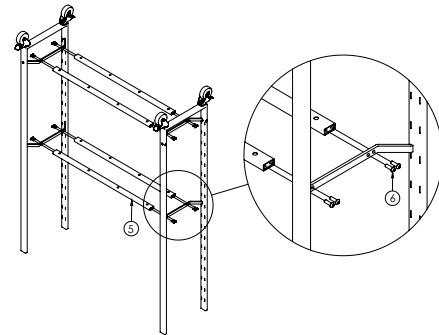

4. Flip the frame assembly and attach the Top Frame with M8x50 Special Socket Screws. ▲ Tighten to 40NM ▲

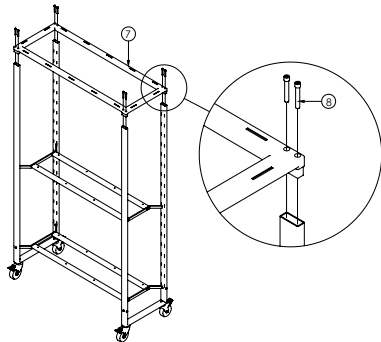

5. Place (x2) Shelf Panels on the fixed Crossbars at the base and middle of the unit. Angle the Panels during insertion, as shown.

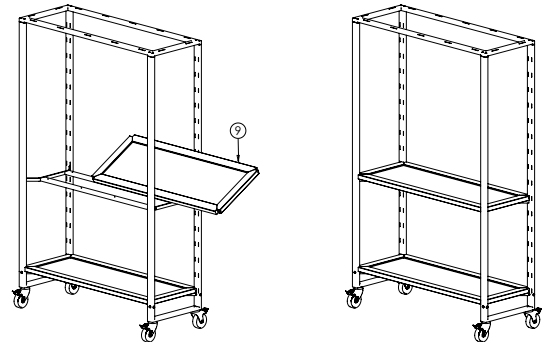

6. To fit Shelf Panels at other heights, insert x4 Shelf Brackets in to the inward column of frame slots at required height.

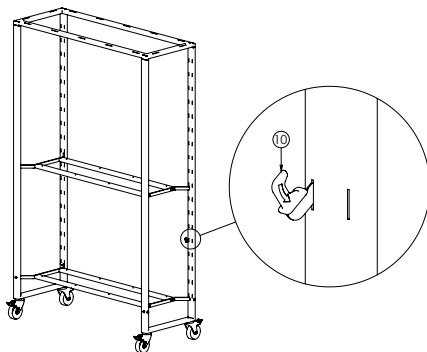

- 6a. Shelf Panels can also be angled by placing rear Shelf Brackets one row higher than the front brackets.

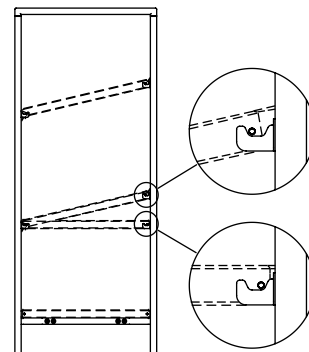

**Company Address**  
 Craster Ltd, Suite 216  
 Great Western Studios, 65 Alfred Road  
 London W2 5EU

**Company Info**  
 VAT Reg No. 599599046  
 Registered in England  
 Company No: 4503732

**UK Telephone**  
 +44 (0) 203 004 4750  
**USA Telephone**  
 +1 732 543 7862

**Email**  
 info@craster.com  
**Web**  
 www.craster.com

## ASSEMBLY INSTRUCTIONS SV\_MOD21

8. Insert Shelf Panels (angle during insertion, as shown) and lower onto Shelf Brackets.

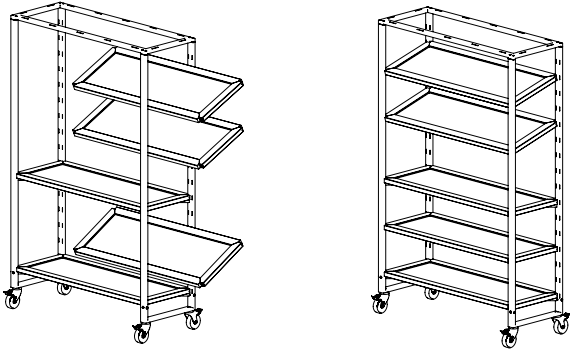

9. To bridge two units together, insert Shelf Brackets into the outward column of frame slots on both units and fit shelf.

