

PRODUCT DATA SHEET

Product Supplier	Craster
Product Name	Tilt Black Frames (includes Mini, Standard and Large)
Codes	BU_RR6231, BU_RR6232, BU_RR6201, BU_RR6202, BU_RR6203, BU_RR6204, BU_RR6205, BU_RR6211, BU_RR6212, BU_RR6213, BU_TR021, BU_TR022, BU_TR023, BU_QR022, BU_QR023
COO	China
Material	Mild Steel
Finish	Powdercoated - RAL9005
Product End Use	Display Stand - not intended for direct contact with food.
Declaration of Compliance	This item is not intended to come into direct contact with Food.
Revision Date	7/08/2024

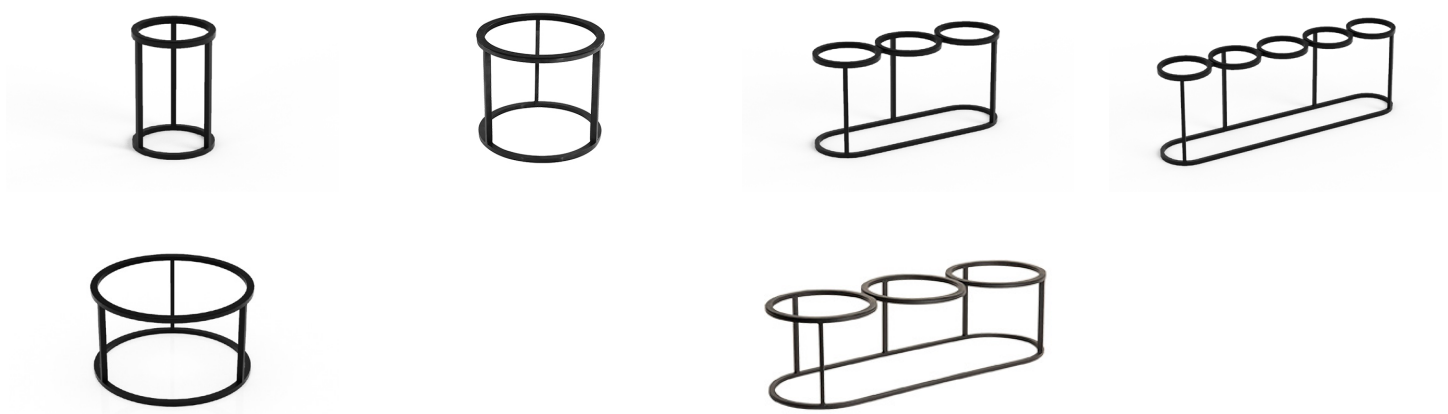

Material Information

The frames are constructed from powder coated mild steel. The frames include plastic feet to stop the frame from damaging counter surfaces, and a rubber gasket ring to stop tilted bowls slipping.

Cleaning & Maintenance

Powder coat:

Powder coating offers a robust decorative surface protection, and prevents the underlying mild steel from rusting. Although the powder coat is tough, it can be damaged by improper use, handling or storage. Take particular care not to knock frames together or against hard surfaces.

Cleaning:

The frames should be wiped clean with a slightly damp non-abrasive cloth, with a mild detergent. Do not use

strong cleaning chemical, alkaline, acidic or bleach.

Storage:

Do not allow the frames to remain in contact with liquids for a prolonged time. Store cleaned and dried frames in a dry location.

Repair:

Small sections of damage can be touched up using Craster touch up pens.

Caution

DO NOT use abrasive cleaning products or chemicals, alkaline, acidic or bleach

DO NOT allow the frames to remain in contact with liquids for a prolonged time

DO NOT use in the dishwasher

Company Address

Craster Ltd
Great Western Studios, 65 Alfred Road
London W2 5EU

Company Info

VAT Reg No. 599599046
Registered in England
Company No: 4503732

UK Telephone

+44 (0) 203 004 4750

USA Telephone

+1 732 543 7862

Email

info@craster.com

Web

www.craster.com